

1. Read carefully and understand all **ASSEMBLY AND OPERATION INSTRUCTIONS** before operating.
2. Failure to follow the safety rules and other basic safety precautions may result in serious personal injury.

GENERAL SAFETY RULES

1. Never overload.
2. Never lift people or animals. Keep children and spectators clear of the area under and around the cargo being lifted. When operating the product, stay clear of the area between the product and the load.
3. Do not contain explosive, flammable substances in the environment of the use of the product.
4. Ensure that the wires and electrical terminals are insulated
5. The support structure and the load connecting device can be selected to withstand the maximum traction of the product.
6. Do not use a failure, can not normally run or damaged products.
7. The service life of the steel wire rope is closely related to the usage ; the new products on the wire rope must be in the case of a load to recover and evenly wound to the drum ; otherwise, improper winding will damage the wire rope.
8. On a regular basis wire rope oiling should use a stiff brush or wood piece, prohibited by hand directly to the working rope oiling.
9. Before the product is used, eliminate any factors or obstacles that may interfere with the safe operation of the product.
10. In tension or load, do not touch the wire rope or hook.
11. Pay attention to the stability of the load during the operation. Do not shake or rotate the load.
12. Do not pull the wire rope over the length of the red paint. Reserve a certain safe length.
13. When the product does not use, repair or replace parts, it is necessary to unplug the power cord in a timely manner.
14. Do not use this product to pull other vehicles. The impact load very easily causes the instantaneous carrying capacity to be more than the carrying capacity of the wire rope or products
15. This product can not be used to fix the load in the running.
16. Do not be inclined to pull in hoisting.
17. When the product does not work, it is not allowed to hang heavy objects in the air to prevent the parts from producing permanent deformation.
18. Do not put any part of the product into the water or wet environment in the use.
19. The correct use of the grounding AC socket through the leakage protection device to protect the socket.
20. Do not operate this product in a humid environment.
21. Avoid being damaged by sharp objects when pulling wires.
22. Keep in mind that the warnings previously discussed cannot cover all possible events and circumstances. It is important that the person setting up, loading/ unloading, and using this product use common sense at all times.

INSTALLATION INSTRUCTIONS

1. First of all, ensure that the Hoist is firmly suspended and reliable.
2. The suspension rod load must be greater than the weight of the weight and hoist.
3. It is strictly prohibited to use the Hoist with overload.
4. It is forbidden to operate with forces other than manpower.

5. Before use, carry out a safety inspection on the Hoist, carry out any-load test on the hoist, and reasonably adjust the position of the lower hook according to the actual requirements.
6. Before lifting, check whether the upper and lower hooks are fastened.
7. When lifting heavy objects, it is strictly forbidden for personnel to do any work or walk under heavy objects to avoid personal injury or accidents.

Remote Control Note:

1. Make sure that the remote control is within use distance and that there are no obstructions around it.
2. Product remote control operation, according to the purchase of the switch, the red light from the wire rope in and out of work.
3. The remote-control transmitter power shortage, more than remote-control distance or serious interference, there will be a slow operation or delay phenomenon, this time should stop the operation, troubleshooting, and then carry out the operation.
4. Do not put the remote control in contact with water or humidity. If there is signal interference, the remote control will cause leakage or damage to the internal circuit. Signal interference will cause the consequences of remote-control.
5. Do not use sharp objects to press the remote control to avoid causing damage to equipment.
6. If not used for a long time, please remove the battery.

The steel wire rope instruction:

1. The operator should understand the situation of the product and be familiar with the performance of the product.
2. Please check before hoisting or traction bracket structure, products, slings, and other accessories are damaged phenomenon. Replace the damaged parts before lifting.
3. Understand the load weight and ensure the rigging, hoisting apparatus and bracket capable of carrying the weight.
4. Check whether the load is under the product or in the same line as the product. The wire rope must not be twisted into bending, and to ensure that all people standing far from the load will not be hurt.
5. Slowly relax the rope and pull up the load if there is an overload phenomenon to reduce the load in time and to adjust.
6. When lifting heavy objects, do not allow rapid lifting to avoid accidents.
7. Please check the wire rope before use. If the wire rope is worn, knotted and damaged, please replace it in time
8. When the wire rope is pulled out, please keep it in light tension to prevent winding and knotting.

Load Note:

1. Do not use a load limiter to stop the load running, and do not close to the cable stop hook.
2. Do not lift or pull any deviation from the center of the load, which may result in the risk of load, to ensure that the load is below the product.
3. Do not swing or wrap around the load.

Overload or overheating:

1. The approximation of the motor force will be displayed on the load display. When the motor is overloaded, the product will stop running, and the two red lights on the monitor will blink until the machine can be used again. This happens to be removed on the wire rope tension to reduce the load. If the sensor overload trips, do not attempt to load the same weight so as to avoid damage to the product.
2. Working for S3--25%, please do not use for a long time. Continuous use will increase the operating process of unsafe factors and severe damage to the motor.

MAINTENANCE

1. Frequently check the condition of the product.

2. Do not use damaged products.
3. Make sure all components are in good condition. If the product or hook becomes damaged through accident, or if any other type of damage is noted, they should be replaced.
4. If the wire rope has become worn or is beginning to show signs of strands breaking it must be replaced before being used again.
5. Keep the wire ropes and hooks from contaminants invasion. Use a clean towel to clean up dirt.
6. Carbon brush will wear for a long time. Please find a professional to replace.
7. Place the product in a dry, clean and protected environment. This product is subject to the provision of European Directive 2012/19/EC. The symbol showing a wheeled bin crossed through indicates that the product requires separate refuse collection in the European Union. This applies to the product and all accessories marked with this symbol. Products marked as such may not be discarded with normal domestic waste, but must be taken to a collection point for recycling electrical and electronic devices.

Parameters

Maximum Lift capacity :500KG / 1100LBS

Wire Diameter : 6mm

Lifting speed : 4m/min

Lifting Height : 7m

Voltage :110V / 50Hz / 1500W

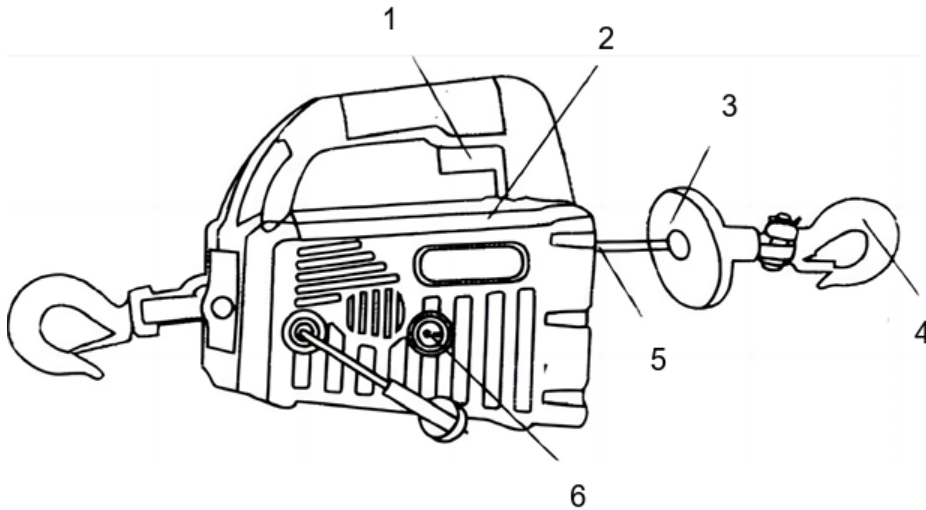

1. Positive and Negative Start Switch
2. Load Indicator
3. Bumper Block
4. Hook
5. Guide Rope
6. Power Switch